

The 'Hilltopper-20'
...a compact 20M CW transceiver.
Offered by the 4-State QRP Group

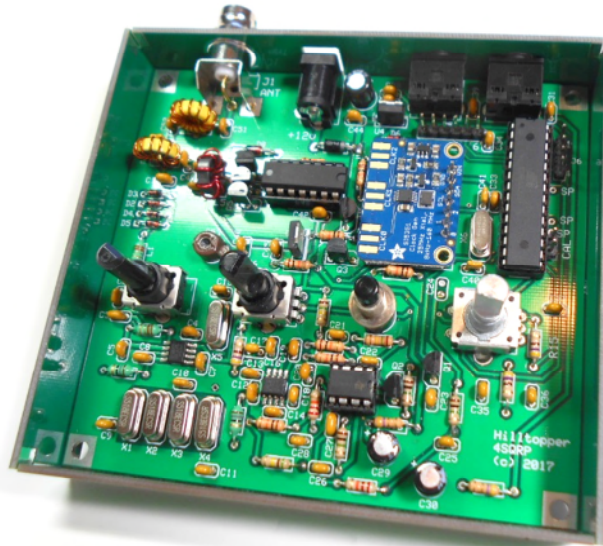

Features:

Frequency coverage: 14.000 to 14.350 MHz
Tuning: 100 Hz /20 Hz steps
Transmitter power output: 5W nominal
Receive current draw: approx.. 60 mA.
Size: 4.35" x 3.95" x 1.07", weight 8 oz.

'On-the-fly' CW speed control. Iambic mode A,
8-35 wpm.
Adjustments: BFO trim cap, one-time
Frequency Calibration
Frequency readout: Audio Morse
SMT Parts (2): Pre-installed

Description:

Receiver: The receiver is adapted from K1SWL's 'SW+' Series with minor modifications. The front-end circuitry was revised to replace the now-vanished 10.7 MHz IF transformers. The output of 1st mixer U1 is transformed to a 220 ohm value by L3/C8. The following crystal filter has a -3dB bandwidth of approximately 400 Hz. L4 and C12 step the impedance back up into the 2nd mixer U2. Trimmer capacitor C53 provides adjustment of the BFO frequency during the alignment process. The two op-amp stages following provide approximately 60 dB of audio gain. The final audio stage is configured as a bandpass filter centered on 800 Hz with a Q of 2. The receiver output is suitable for headphone use. An 800 Hz sidetone is injected into this final stage.

Transmitter: The transmitter strip closely resembles Steve Weber's – KD1JV- fine work. The frequency source for both transmitting and receiving is an Adafruit Si5351 board. This board outputs a 3V p-p square wave. The 'CLK1' signal is enabled (turned on) during Transmit directly at the operating frequency. The 'QSK' signal further 'gates' the CLK1 signal to eliminate a 'back-wave' between code elements. U7's three remaining gates are paralleled for higher current drive into the PA devices Q5-Q7. The low-pass filter design is based on a drain impedance of 10 ohms and was optimized using the ELSIE modelling application. The addition of C52- in parallel with L7 provides a notch to reduce the 2nd-harmonic content to FCC-compliant levels.

Wave-shaping: Q4 is a P-channel MOSFET rated for 2A continuous duty -with proper heatsinking- and is turned on when Q3 is on, conducting current to ground. Capacitor C45 serves to make the supply voltage rise and fall linear. Rise time is 2 mS and fall time is 4 mS. Note: R17, R18 and R21 are 'insurance', ensuring that the PA stage and supply bias are firmly OFF during initial power-up.

MPU Controller: The controller IC is a 28-pin DIP- the Atmel ATmega328P used in the Arduino UNO. It relies on an external 16 MHz crystal (Y6) for its timing. The application firmware was written in the Arduino environment (more on this later). An on-board rotary encoder outputting 24 pulses-per-revolution provides a tuning function. The variable DC voltage provided by Speed pot R16 is read by an A/D converter and scaled for Morse code timing. A pair of inputs are used for dot/dash paddles, and Straight-key mode is also available. The remainder of the I/O provides various control signals and sidetone for a variety of operations.

Firmware: The Hilltopper firmware was written in Arduino's (mostly) C language and supported by its own compiler. After power-up initialization, the main program runs in a fairly high-speed loop, awaiting keyer and pushbutton inputs. Encoder phase A is handled by a brief interrupt routine. That routine flags the presence of a new tuning input and reads phase B to determine its up/down tuning direction. Outputs 'A4' and 'A5' provide a clock and serial data to the Si5351 board. During Receive operation, CLK0 is active, and its output equals the operating frequency plus the IF. During Transmit, CLK1 is active directly at the operating frequency. The changeover is a fairly slow process, requiring a number of data bytes be sent to the Si5351 at a fairly low bit rate. To avoid having to keep switching back and forth between code elements, there's a 50 mS 'hang' time on key-up.

Note: The Hilltopper firmware is **open-source** and can be downloaded from :

<https://4sgrp.groups.io/g/HilltopperKit> See the 'files' section. Please note that J5 and J6 – 0.100" headers- are not provided in this kit. Those folks interested in code-bashing will know what to do. *J6 is intended to facilitate the future use of Serial LCD displays.*

Parts list:

Qty.	Reference designator	Description	Notes/ markings
2	C6, C15	10 pF C0G cap	
2	C40, C41	22 pF C0G cap	
5	C1,C3,C8,C12,C16	47 pF C0G cap	
1	C53	12-60 pF trim cap	brown
2	C17,C52	68 pF C0G cap	
3	C7,C9,C11	100 pF C0G cap	
2	C2,C10	150 pF C0G cap	
1	C49	220 pF C0G cap	
1	C51	270 pF C0G cap	
4	C21,C22,C24,C50	470 pF C0G cap	
1	C26	820 pF C0G cap	
1	C27	.0022 (2200 pF) C0G cap	
10	C4,C5,C13,C14,C31,C37,C38,C39 C47, C54	.01 uF cap	
1	C18	.033 uF cap	
15	C19,C20,C23,C25,C28,C32,C33, C34,C35,C36,C42,C44,C45,C46 C48	0.1 uF cap	
3	C29,C30, C43	100 uF electrolytic cap	

All resistors are $\pm 5\%$ tolerance $\frac{1}{4}$ watt.

2	R13, R23	4.7 ohm	Yellow-violet-gold-gold
2	R14, R15	470 ohm	Yellow-violet-brown-gold
1	R22	1.0K ohm	Brown-black-red-gold
2	R1, R16	5K potentiometer, PCB mount	
8	R2, R3, R11, R17-R21	10K ohm	Brown-black-orange-gold
2	R8, R9	22K ohm	Red-red-orange-gold
2	R4, R5	150K ohm	Brown-green-yellow-gold
1	R10	510K ohm	Green-brown-yellow-gold
3	R6, R7, R12	1.0M ohm	Brown-black-green-gold

1	CAL	2-pin male header, .100"	
1	CAL	2-pin female jumper	

1	D1	1N5818 diode	Black case
4	D2, D3, D4, D5	1N4148 diode	Glass case, small
2	D6, D7	BAT85 diode	
1	D8	1N4756 diode	Glass case, larger

1	J1	BNC jack, right-angle mount	
1	J2	DC power jack	
2	J3, J4	Key and audio jacks, 3.5mm 3-cond.	
--	J5	6-pin .100" male header	not supplied in kit
--	J6	4-pin .100" male header	not supplied in kit

2	L1, L2	3.3 μ H RF choke	Orange-orange-gold-gold
2	L3, L4	18 μ H RF choke	Brown-grey-gold-gold
1	L5	FT37-43 toroid	See group 7 instructions
2	L6, L7	T37-2 toroid	See group 7 instructions

5	Q1, Q3, Q5, Q6, Q7	BS170 MOSFET	
1	Q2	J113 JFET	
1	Q4	NTD2955	Small heat sink tab
2	U1, U2	SA612AD 8-pin SOIC-8 IC	(pre-installed)
1	U3	NE5532	8-pin DIP IC
1	U4	LM78M05	Small heat sink tab
1	U5	ATmega328P	28-pin DIP IC
1	U6	LM78L05	
1	U7	74AC08	14-pin DIP IC

Miscellaneous:

1	--	Si5351 board	Supplied with 8-pin header strip. See group 3.
1	SW1	pushbutton switch	
2	--	1/8" plastic spacer	Used with pushbutton sw
1	SW2	rotary encoder w/ switch	
5	X1-X5	5.185 MHz HC-49/US crystal	Matched set
1	X6	16 MHz HC-49/US crystal	
1	--	#24 magnet wire	18" (45 cm) length
1	--	#21 magnet wire	24" (60 cm) length
3	--	Knobs	
4	--	1/4" #4 spacer	
4	--	5/8" #4 spacer, threaded	
4	--	#6-32 x 1/4" machine screw, pan head	
4	--	#6-32 x 3/8" machine screw, pan head	
1	--	8-pin DIP socket	
1	--	14-pin DIP socket	
1	--	28-pin DIP socket	

Assembly- general notes:

A number of components are polarity-sensitive: all semiconductor devices and diodes....and the three electrolytic capacitors.

Capacitors these days are tiny! In sunlight, I can read their printed values with +3.0 reading glasses. Most of the time, though, I use a 10-power eye loupe (~\$3-4 from DigiKey). Likewise, the adjustment slot on trim cap C53 is tiny as well. An eyeglass repair kit (\$2 at discount stores) has just the right teensy screwdriver.

Assembly sequence: You'll find 7 grouped assembly sequences in these pages. You don't have to follow them. **Caution:** There's one component installation where the order matters. That's diode D7, which is *under* the Si5351 board. Install it before you add the Si5351 board. It's also

important to ensure that the on-board connectors are installed 'square and plumb' to the PC board surface.

BEFORE YOU START

Before getting started with building the Hilltopper 20, take some time to organize and familiarize yourself with the parts provided and check them against the Parts List. Building over a cookie sheet is recommended to minimize parts being lost. To prevent static damage, it is recommended that the ICs not be removed from their anti-static packaging until you are ready to install them. If parts are missing in your kit, send an email to the Hilltopper kitter listed at 4SQR.com. He will promptly provide replacements.

It is helpful to acquire the necessary tools and supplies before beginning. These include:

- *Soldering iron – 20 to 30W, preferably thermostatically controlled.
- *Fine 60/40 rosin core solder
- *Diagonal cutters
- *Needle-nose pliers
- *Fine file or emery board
- *Flat blade and Phillips screwdriver

Schematic and Component Placement diagrams are provided as part of documentation package. It is highly recommended to print a copy for reference during construction. As you build, you can check off each construction step as you complete them in order. When you think you are done, you can check the list to verify that all of the parts have been installed.

Snap off the enclosure sides from the sides of the two main boards. The boards are scored with a V-groove so that they break free readily. Once separated, lightly sand the rough edges of the breaks until smooth.

Further details may be found in the grouped assembly sequences. ***Let's get started!***

Online Support: Search for 'Groups.io' on your browser and register to use their free service. Find '4SQR.groups.io' and register to join. Once approved, find the HilltopperKit subgroup and register for it in turn. This is a group e-mail reflector and supports images and other file types. **Please note that the J5 and J6 header strips are not provided in this kit-** See the 'Files' section of the subgroup for more information.

GROUP 1 ASSEMBLY:

- Install all (qty.15) 0.1 μ F capacitors. These are labeled '104' on one side. Restrain each capacitor by spreading the leads apart on the underside of the board until you can solder it. / typically install 3 or 4 components, then solder each and clip off the excess lead length. Locations are highlighted below.

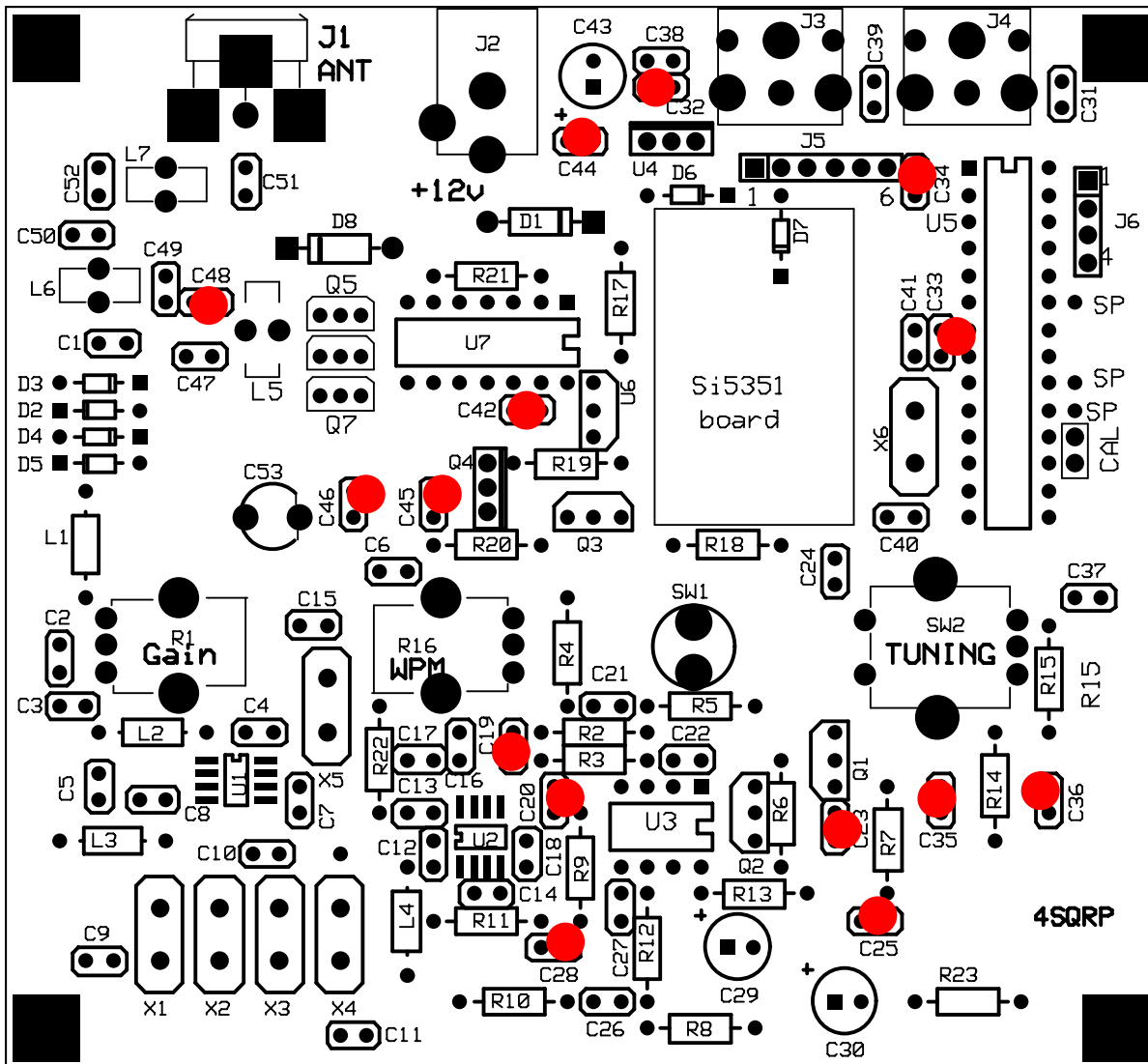

GROUP 2 ASSEMBLY:

- Install all (qty. 9) .01 μF capacitors. These are labeled '103' on one side. Restrain each capacitor by spreading the leads apart on the underside of the board until you can solder it. *typically install 3 or 4 components, then solder each and clip off the excess lead length.* Locations are highlighted below.

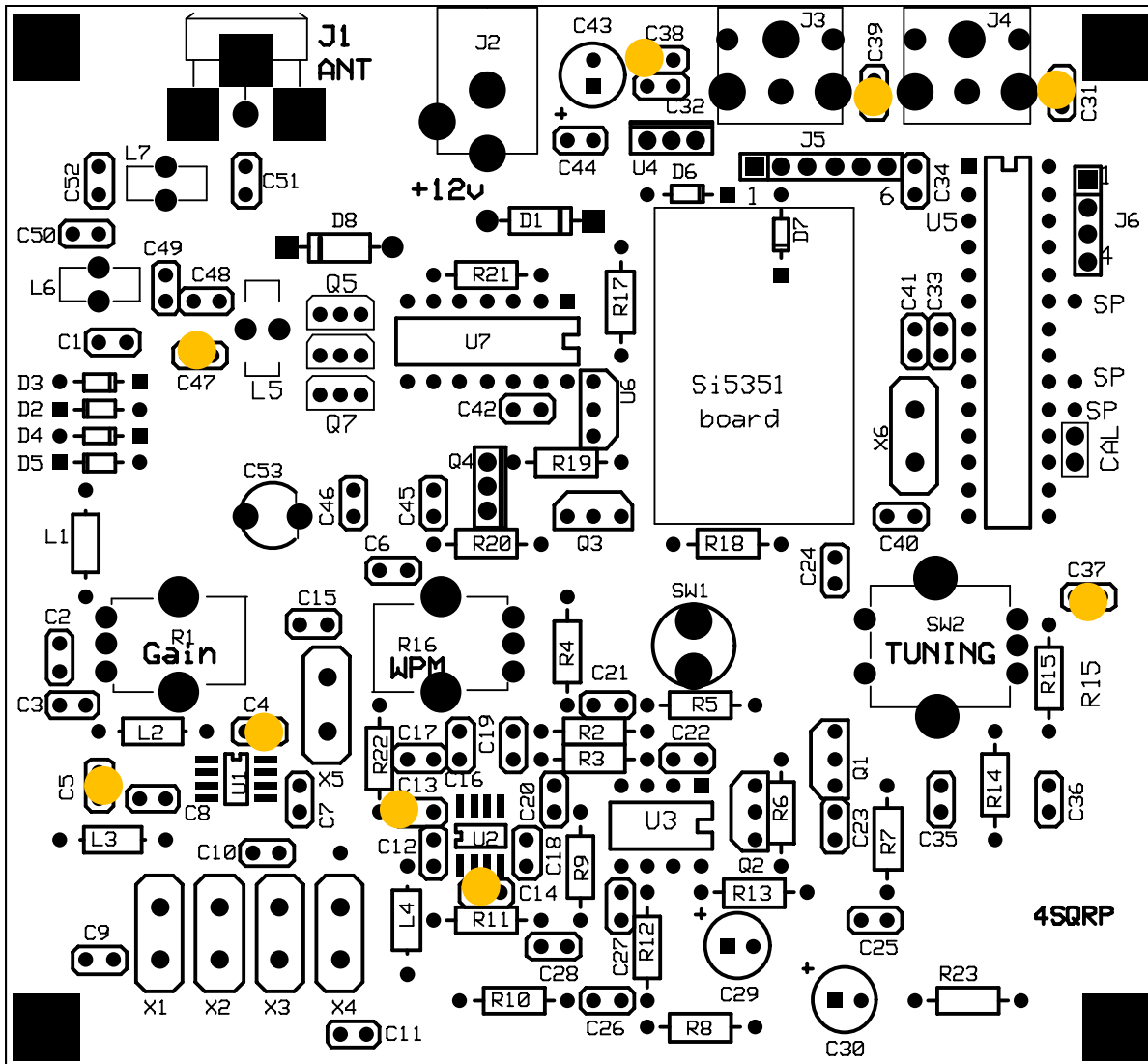

GROUP 3 ASSEMBLY:

- Install all components highlighted below. Some parts are in the static sensitive bag, with the remaining parts used in future steps. The A detailed assembly sequence follows the illustration.

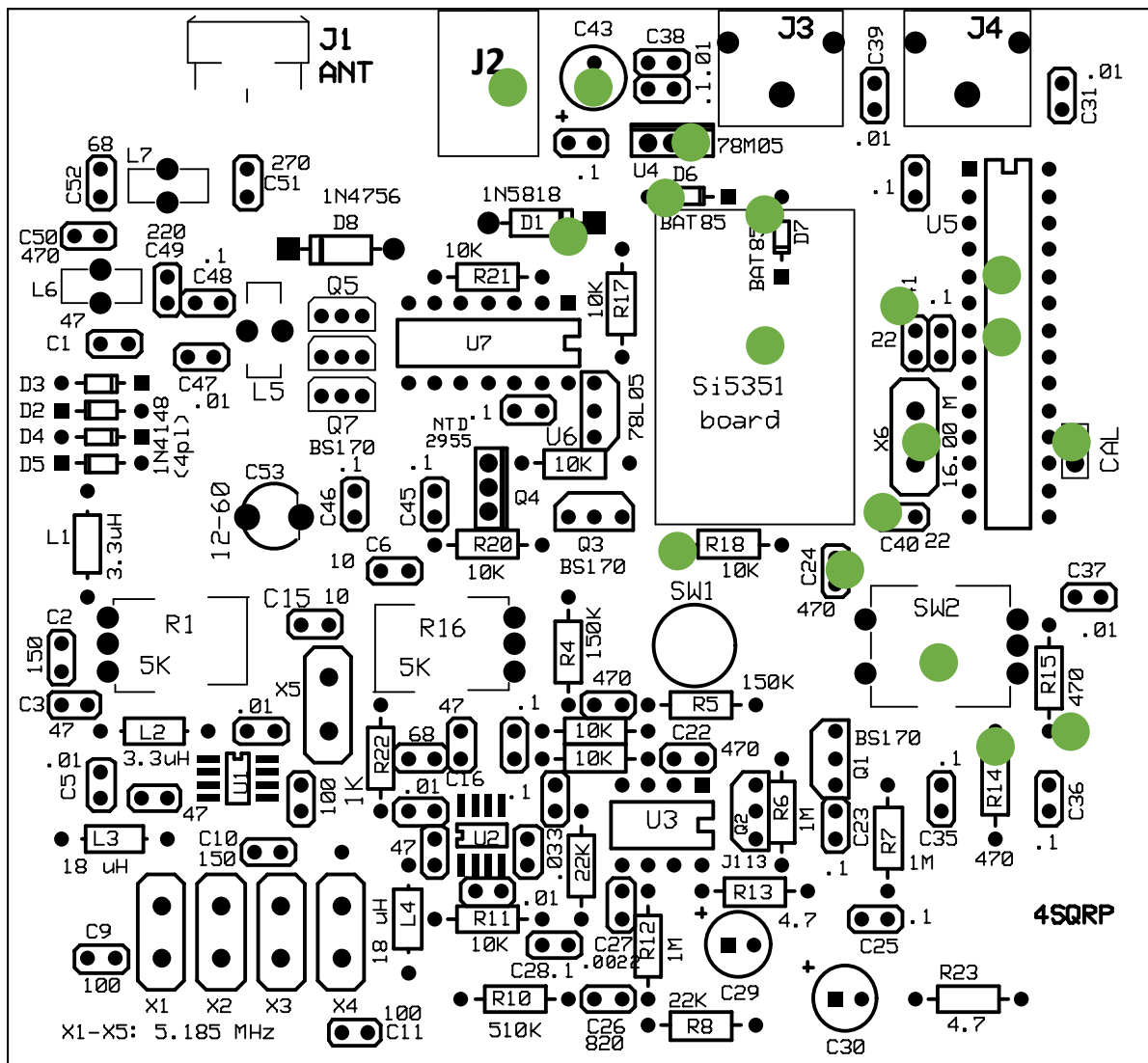

rev. 11/7/2017

- Install DC power connector J2. Use a ¼-inch wide elastic band to hold the connector in place temporarily. **Solder only one lead at first.** Flip the board back over and check to ensure that the connector is aligned squarely on the board. Reheat the connection if needed to align the connector properly. Once the alignment is OK, solder the remaining leads on the connector.

- Install power diode D1 (1N5818) and bias diodes D6 and **D7 (BAT85)**. Be sure to match the banded end of the diode to that shown on the illustration. **D7 must be installed before the Si5351 board is installed.**
- Install electrolytic cap C43 (100 μ F). This part is polarity sensitive. Install so the white band on the case faces the rear of the board. *This also corresponds to the shorter wire lead.*
- Install U4 (78M05) This part is polarity sensitive. Install so that its heat-sink tab faces the rear of the board as illustrated.
- Install capacitors C40 and C41 (marked '220' or "22J") and X6 (16.00 MHz). *I use a narrow (0.1") strip of paper under the crystal can to stand the crystal slightly above the board. Once at least one of the leads is soldered, the paper is removed.*
- Install resistor R18 (10K ohm, brown-black-orange-gold)

- Prepare the Si5351 board. Cut one pin off the 8-pin header supplied with the Si5351 and mate the 7-pin strip to the board. **Save the cut-off pin.** Make sure the insulated portion of the header is on the underside of the Si5351 board. Solder just one pin on the header strip. Check your work to ensure the header strip is firmly and squarely seated on the small board. Once it's OK, solder the remaining pins.

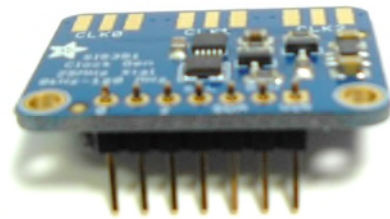

- Install resistors R14 and R15 (470 ohm, yellow-violet-brown-gold).
- Install the Si5351 on the main circuit board. Place the cut-off header pin) under the edge of the Si5351 board to ensure that the board is level. Tape down the Si5351 board and the header pin using transparent tape. Flip the board over and solder one pin of the 7-pin strip to the main board. As before, check your work and then solder the remaining pins. Remove and discard the tape and single header-pin. (Cut off excess lead length on the underside of the board.)



- Install the 28-pin IC socket at U5. The notch at one end of the socket faces the rear of the board as shown. If you install it backwards- leave it! The socket itself is not polarity-sensitive.
- Install capacitor C24 - 470 pF (marked '471')

- Install 28-pin IC U5 (ATmega328P). This device is polarity-sensitive. The dot and or/ notch at one end of the device must face the back of the board. You will need to bend the IC pins gently inward to mate with the socket. The best approach is push the IC down on a hard surface to bend one 14-pin row at a time evenly. Once

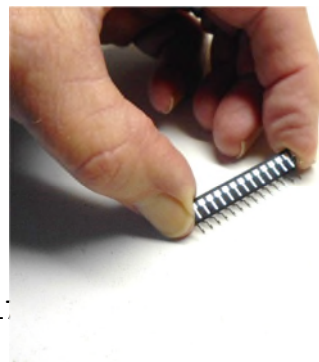

you've installed the IC, ensure that all leads are seated in the socket.

- Install the 2-pin male header at the location identified as 'CAL' . (Keep the mating 2-pin female jumper aside until construction is complete.)

GROUP 4 ASSEMBLY:

- Install all components highlighted below. A detailed assembly sequence follows the illustration.

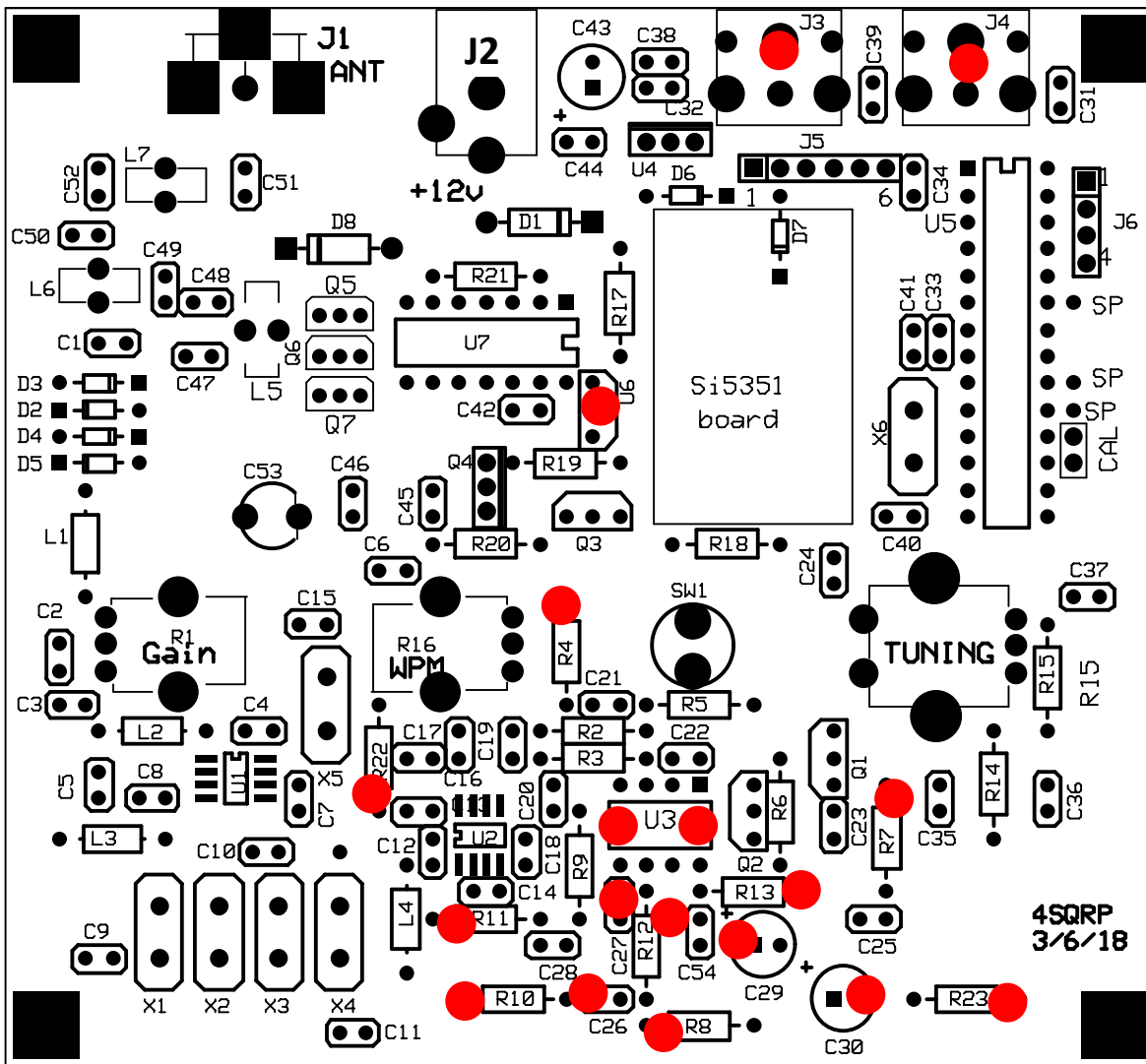

- Install J3 and J4.
- Install U6 (78L05). Observe proper orientation on the board.

- Install resistor R4 – 150K ohm (brown-green-yellow-gold)
- Install resistor R22 - 1K ohm (brown-black-red-gold)
- Install resistor R11 – 10K ohm (brown-black-orange-gold)
- (continued)
- Install resistor R10 – 510K ohm (green-brown-yellow-gold)
- Install the 8-pin DIP IC socket at U3. The notched end of the socket faces to the right.
- Install the NE5532P IC at U3. This part is polarity-sensitive. Ensure that the notch/dot on the IC faces to the right.
- Install capacitor C27 (.0022 uF, '222')
- Install capacitor C26 (820 pF, '821')
- Install capacitor C54 (.01 μF, '103')
- Install resistors R7 and R12 (1M ohm, brown-black-green-gold)
- Install resistors R13 and R23 (4.7 ohm yellow-violet-gold-gold)
- Install resistor R8 (22K ohm, red-red-orange-gold)
- Install electrolytic caps C29 and C30. Observe installation polarity. The longer wire lead corresponds to the positive (+) side of the cap.

GROUP 5 ASSEMBLY: • Install components highlighted below. A detailed assembly sequence follows.

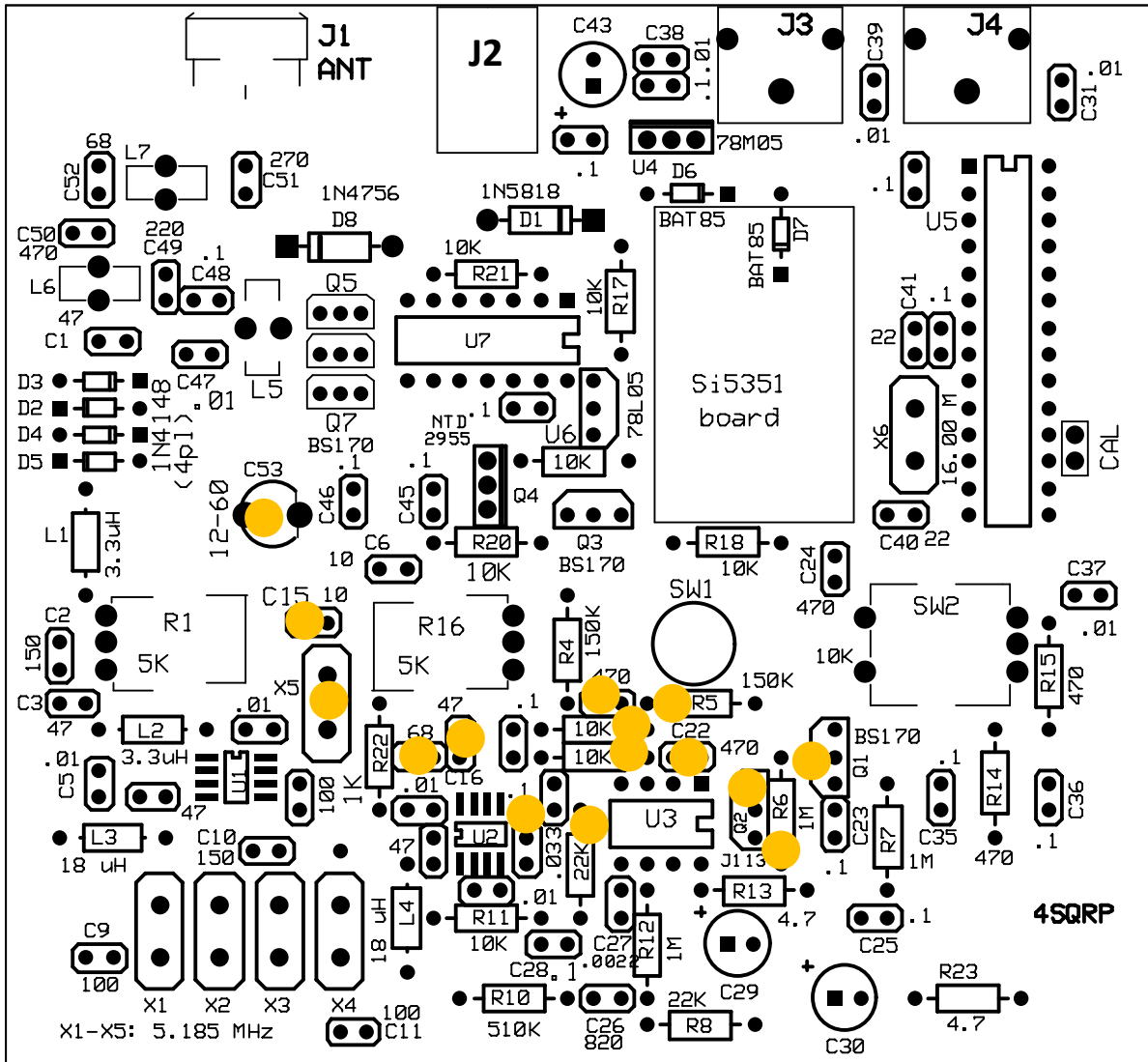

rev. 11/7/2017

- Install transistor Q1 (BS170). The 'flat' on the side of the transistor faces right.
- Install resistor R6 - 1M ohm (Brown-black-green-gold))
- Install transistor Q2 (J113). The 'flat' on the side of the transistor faces right.
- Install resistor R5- 150K ohm (Brown-green-yellow-gold)
- Install capacitors C21 and C22 - 470 pF (marked '471')
- Install resistors R2 and R3- 10K ohm (Brown-black-orange-gold)
- Install resistor R9- 22K ohm (Red-red-orange-gold)
- Install capacitor C18 - .033 uF (marked '333')
- Install capacitor C16 - 47 pF (marked '470' or '47J')
- Install capacitor C17 - 68 pF (marked '680' or '68J')

- Install crystal X5 – 5.185 MHz This is one of a matched set of 5 crystals, and may be used interchangeably within the group
- Install capacitor C15 - 10 pF (marked '100' or '10J')
- Install trimmer capacitor C53 - 12-60 pF (brown). The 'flat' side of the capacitor faces right.

GROUP 6 ASSEMBLY: • Install all components highlighted below. A detailed assembly sequence follows.

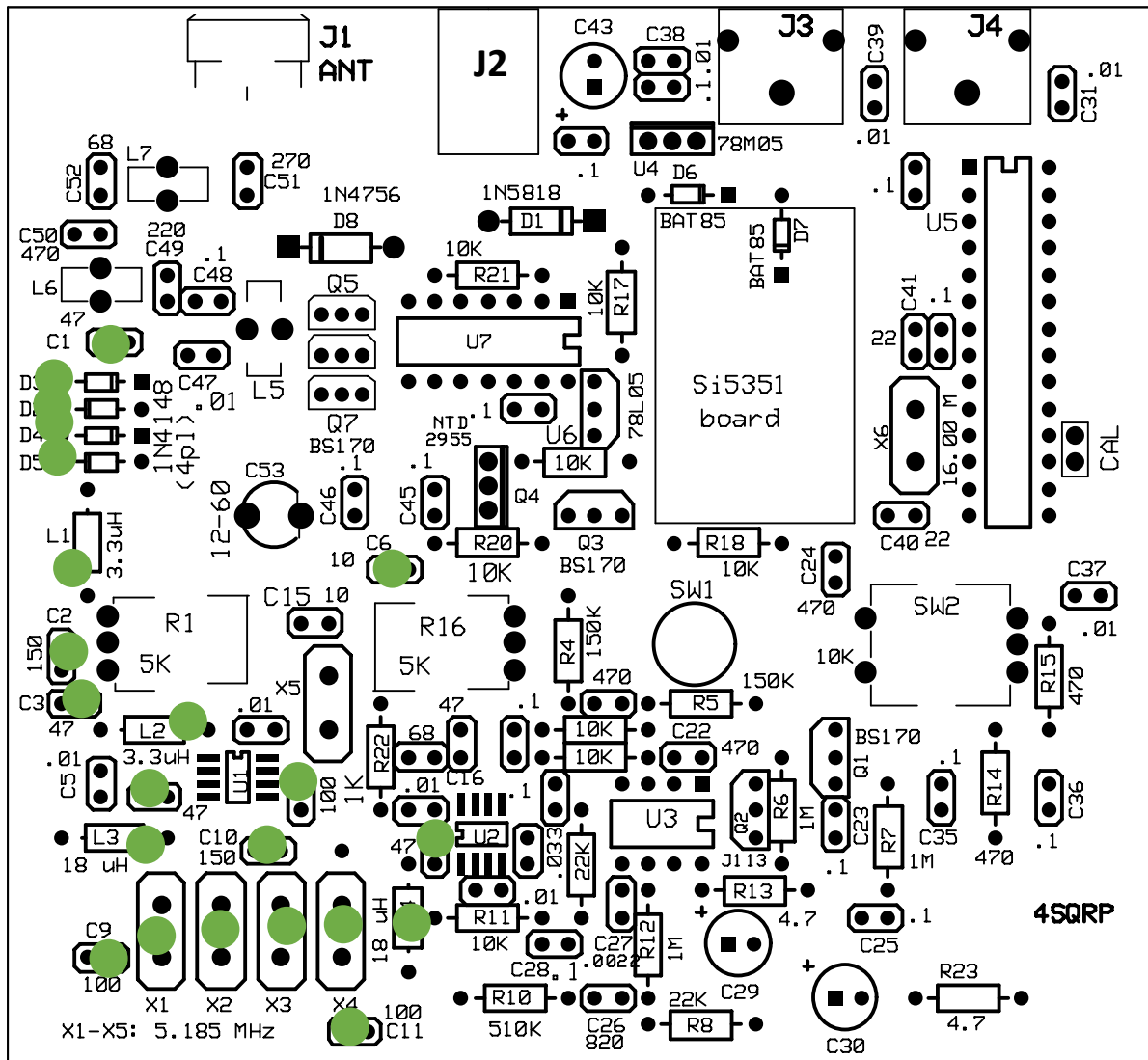

rev. 11/7/2017

- Install capacitors C1, C3, C8 and C12 - 47 pF (marked '470' or '47J').
- Install capacitor C6 - 10 pF (marked '100' or '10J').

- Install RF chokes L1 and L2 – 3.3 Uh. These are slightly larger in diameter than the resistors. They're marked with **two orange bands** – and several more bands which may vary in color.
- Install capacitors C2 and C10 - 150 pF (marked '151').
- Install capacitors C7, C9 and C11 - 100 pF (marked '101').
- Install RF chokes L3 and L4- 18 Uh **Brown-blue bands.**
- Install crystals X1 through X4 – 5.185 MHz. As in the group 3 assembly, a narrow (0.1") strip of paper temporarily stands the crystals slightly above the board.
- Install diodes D2 through D5 - 1N4148. Be to match the banded end of each diode to the banded marking on the circuit board component outline. **Note: D3 and D4 bands to the right, D2 and D5 bands to the left.**

GROUP 7 ASSEMBLY: • Install all components highlighted below. A detailed assembly sequence follows.

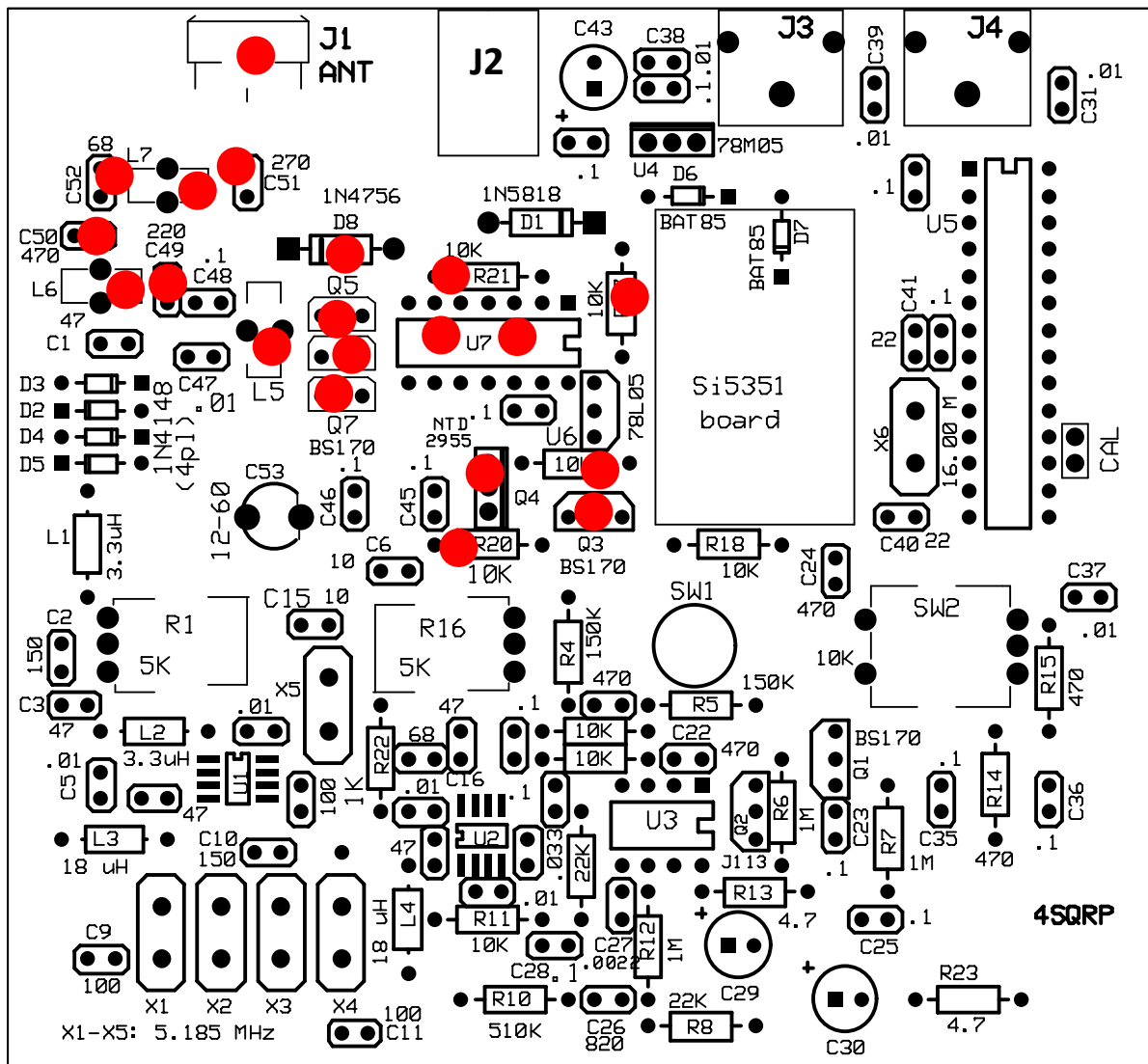

rev. 11/7/2017

- Install R17, R19, R20 and R21 - 10K ohm (brown-black-orange-gold).
- Install Q4 (NTD2955). **Ensure that the heat-sink 'flat' faces to the right as shown.**
- Install the 14-pin IC socket at U7. **The notch on the socket faces to the right as shown.**
- Adjust the lead spacing on U7 as needed. **See images in group 3.** Install U7, ensuring that **the dot/notch on the IC body faces to the right**
- Install transistors Q3, Q5, Q6, and Q7, (all BS170s) observing the installation polarity as shown above.
- Install Diode D8 (1N4756).
- Install capacitor C49 - 220 pF (marked '221').
- Wind 8 turns of #21 (thicker) wire on toroid L5 (FT37-43 gray toroid). Trim excess lead length to 3/8" (1 cm). Using a small knife, gently scrape the insulation from the protruding leads. (*The insulation will not melt when you apply a soldering iron.*)

- Install L5.

A properly-wound toroid looks like this.

Note the following:

- Each time the wire goes through the hole it counts as a turn. Doublecheck your work.
- The winding is evenly-spaced around the core.
- The leads are stripped prior to installation.
- The windings are tight. I pull the wire taut after each turn comes up over the outer edge of the core.

- *and please...* no scrambled turns!

- Using a 10" piece of the #24 (thinner) magnet wire, wind 12 turns on a T37-6 (yellow) toroid. Prepare the leads as above and install at L6.

- Using a 12" piece of the #24 (thinner) magnet wire, wind 14 turns on the remaining T37-6 (yellow) toroid. Prepare the leads as above and install at L7.

- Install capacitor C50 - 470 pF (marked '471').
- Install capacitor C51 - 270 pF (marked '271').
- Install capacitor C52 - 68 pF (marked '680' or '68J').

- Install BNC bulkhead jack J1. Use sandpaper or file to roughen plating to ensure a good solder joint.

(This completes assembly of the main circuit board.)



(GOOD TOROID)



BAD TOROID!
(bad bad toroid!)

Final assembly:

- 1) Install four 5/8" (1.5 cm) threaded spacers at the corners of the top cover using the shorter 1/4" screws as shown at right.
- 2) Add one each end and side-panels. When they're properly aligned, the tabs and notches at the ends of each panel will interlock cleanly. **The front/rear panels have tabs. The side panels have notches.** When these are in place, hold the panels in tension by placing an elastic band around them as shown.
- 3) Put top cover in place. This is to ensure proper placement of the circuit board and to ensure side pieces are square.
- 4) Flip the assembly over. Insert the circuit board upside down into the unit with board resting against the spacers attached to the top.
- 5) There are bare tinned areas on each side panel. These must line up with the corresponding bare areas on the main circuit board. Solder all 6 pairs of contact points between the main board and the panels. **Make sure the panels line up with the edges of the cover.** **Caution – side panels get hot quickly and can cause painful burns.**
- 6) Solder the upper and lower inside corners of the panels (8 pl. total). *This adds considerably to the enclosure strength.*
- 7) Remove the elastic band and the top cover.
- 8) Remove the top cover and set it aside.
- 9) Install the controls – pots R1, R16, switch SW1 and rotary encoder SW2. Discard the nut and washer that comes with the rotary encoder. Place the two white 1/8" spacers on pushbutton switch SW1's leads and install SW1. Then tack one lead on each to hold them in place. Fit the top cover to ensure the controls will align with holes. Holding the top cover, turn unit over and complete soldering the controls.
- 10) Perform the Alignment and BFO Pitch Adjustment processes as described in the next section.
- 11) Replace the top cover with spacers.

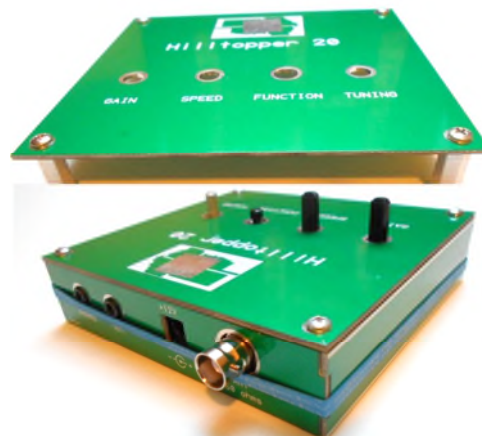

A word about soldering:

The tinned areas are thermally-isolated from the rest of the board material. 25 to 40W iron and a fine point tip are sufficient. Do not use a high-wattage iron! A proper connection shows a smooth transition across the joint and not 'two rounded bumps'



- 12) With the unit upside down, rest it on something so controls are held above the work surface, set a spacer over each hole, carefully lay the cover on, then push the remaining $\frac{5}{8}$ " screws through the holes and spacers. Use a screwdriver, first turning counter-clockwise until you feel each one seat, and then turn clockwise to tighten.
- 13) Install knobs on the three controls, using a small slot screwdriver on the setscrews. Space the knobs slightly above the panel to prevent 'rubbing'. The tuning knob must be just high enough to allow the detent switch on the rotary encoder to function.

(This completes assembly of the kit.)

ALIGNMENT:

There are two steps in the alignment process. The frequency calibration is performed first.

- 1) Frequency Calibration
- 2) BFO pitch adjustment

Frequency Calibration:

The Si5351 DDS board uses a standard-quality SMD crystal as its reference clock. As such, your operating frequency may be off by a kHz or so at 14 MHz.

PROCEDURE:

- 1) Tune your 'big rig' to 14060.00 kHz
- 2) Install the 2-pin female jumper at the location marked 'CAL' to the right of U5.
- 3) Connect a 50-ohm load to J1. A matched antenna is OK.
- 4) Apply 10-14V DC power to J2 via a 2.1/5.5mm male plug.

Upon power-up, the Hilltopper will put out full power (5W nominal) for 5 seconds. During that time, rotate the TUNING control to match the tone in your 'big rig' to your sidetone pitch. At the end of 5 seconds, the transmitter stops transmitting and a calibration factor is calculated and stored in U5's EEPROM. That value is retrieved on subsequent power ups

It's possible you won't find 5 seconds to be enough time for the calibration. If that's the case, remove-and restore- DC power. The 5-second routine starts over, allowing you to zero in on the correct frequency.

Alternate method: Connect a frequency counter to the center pin (and ground) and apply D-C power. Adjust the tuning control as above.

IMPORTANT: Remove the jumper at the 'CAL' location when this calibration is completed. Remove
-and restore- DC power to proceed to normal operation.

BFO Pitch adjustment:

The quick method:

Tune in a CW station and adjust trim cap C53 using a teensy screwdriver. You're looking for maximum signal strength at the same pitch as the sidetone (800 Hz). It's a 2-handed operation, since you also need to work the tuning knob.

'The better method:

Power up the hilltopper (it starts up on 14060.0.) Set your big rig to 14060.0 and send a string of dots (low power, please!). Adjust C53 so that the received pitch in the Hilltopper matches your sidetone pitch.

* * *

Operation:

Startup: Upon applying DC power to the Hilltopper, you'll hear '6 o R o'. In the headphones. This indicates an operating frequency of 14060.0 Khz. If you tune above 14100, the readout will be in the form of '1xx.x'.

Frequency Readout:

Push the FUNCTION switch briefly to hear your current frequency. *The readout is at the same speed as you keyer speed setting.*

Tuning step size:

Briefly pressing the tuning knob toggles the step size between 100Hz and 20Hz. The power-up default is the 100 Hz step size.

RIT: Push and hold the tuning knob down for at least a half-second. A two-tone sequence, 'boo-beep' indicates that RIT is on. Repeat to turn RIT off- it's annunciated by 'bee-boop'.

TUNE Mode *(Not applicable to straight key operation):*

Push and hold the Function switch for at least a half-second. The sidetone and Transmitter output turn on to allow adjustment of antenna tuners, etc. It stays in TUNE mode until:

- 5 seconds has elapsed
(or)
- either keyer paddle is tapped

Paddle Reverse:

Before applying DC power to the Hilltopper, press AND HOLD the FUNCTION switch. Apply DC power to the Hilltopper. Release the FUNCTION switch as soon as you hear the Morse frequency annunciation start. *(Note: this setting is stored in non-volatile memory. It shouldn't need to be changed often.)*

Straight Key mode:

Upon power-up, the Hilltopper firmware checks the state of the 'ring' (middle) connection on the keyer jack. If a 'mono' (2-pin) plug is used, that middle connection is grounded, and the Hilltopper automatically follows the straight key or external keyer input.

Alternate Startup Frequency:

Pressing the TUNING switch down while applying DC power to the Hilltopper yields a startup frequency of 14030.0 kHz. The readout in this case is '3 o R o'. This saves a lot of knob-twisting if you usually work the low end of 20M.

Receiver Schematic:

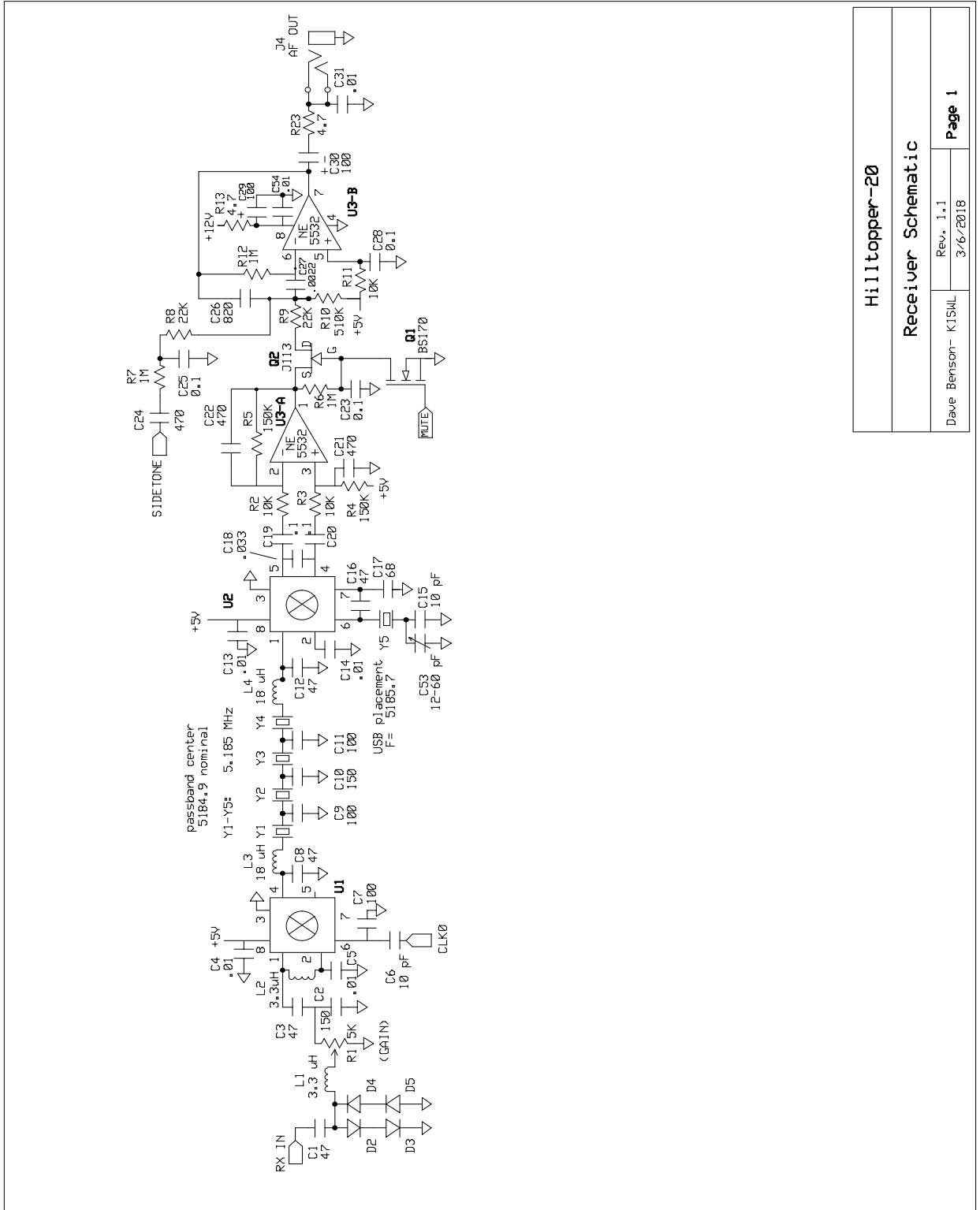

Hilltopper-20	
Receiver Schematic	
Dave Benson- K1SWL	Rev. 1.1 3/6/2018
Page 1	

Transmitter/Controller Schematic:

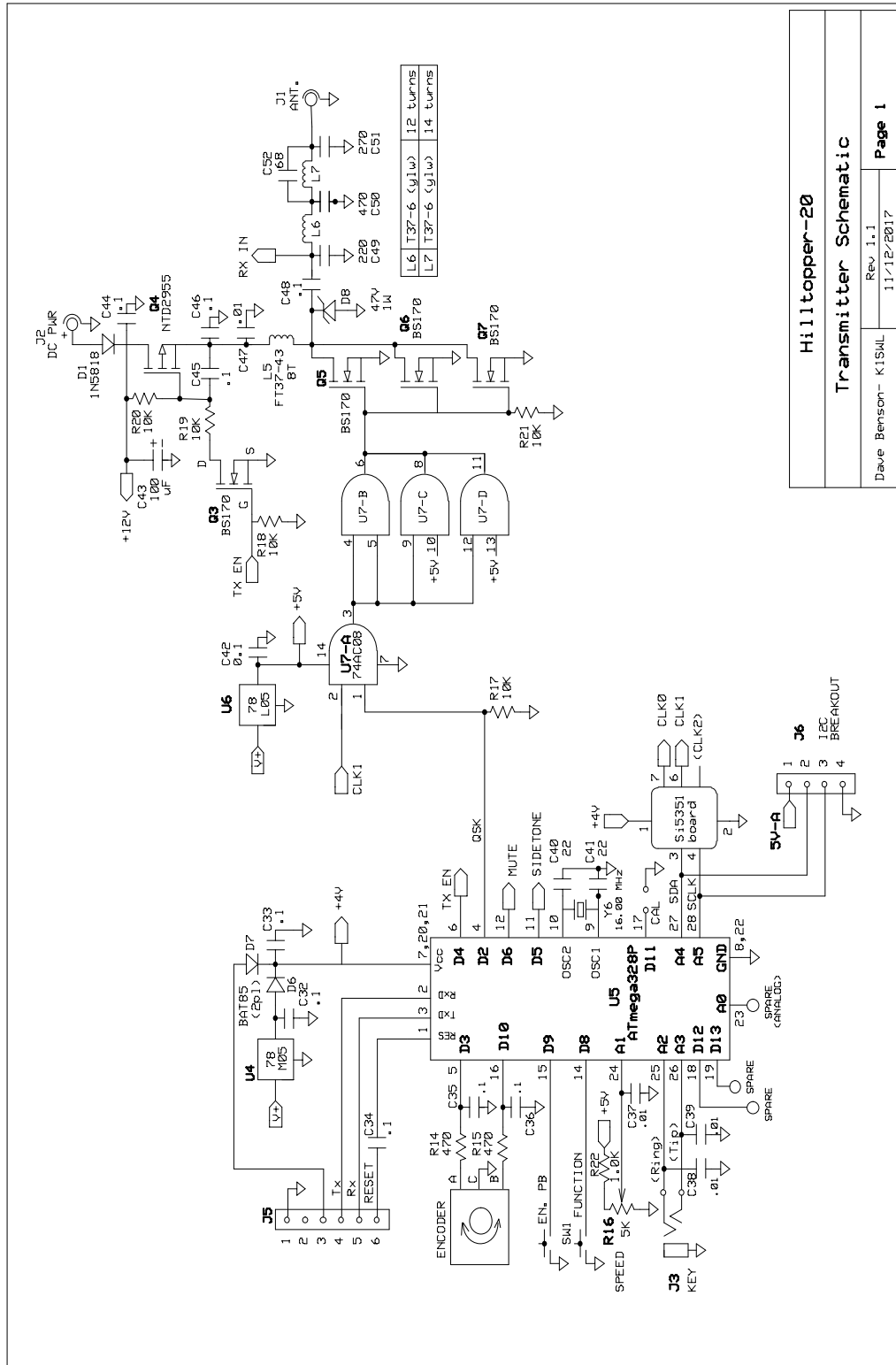

Hilltopper-20

Transmitter Schematic

Rev 1.1
11/12/2017

Dave Benson- K1SUL

Page 1

Component Placement – Master

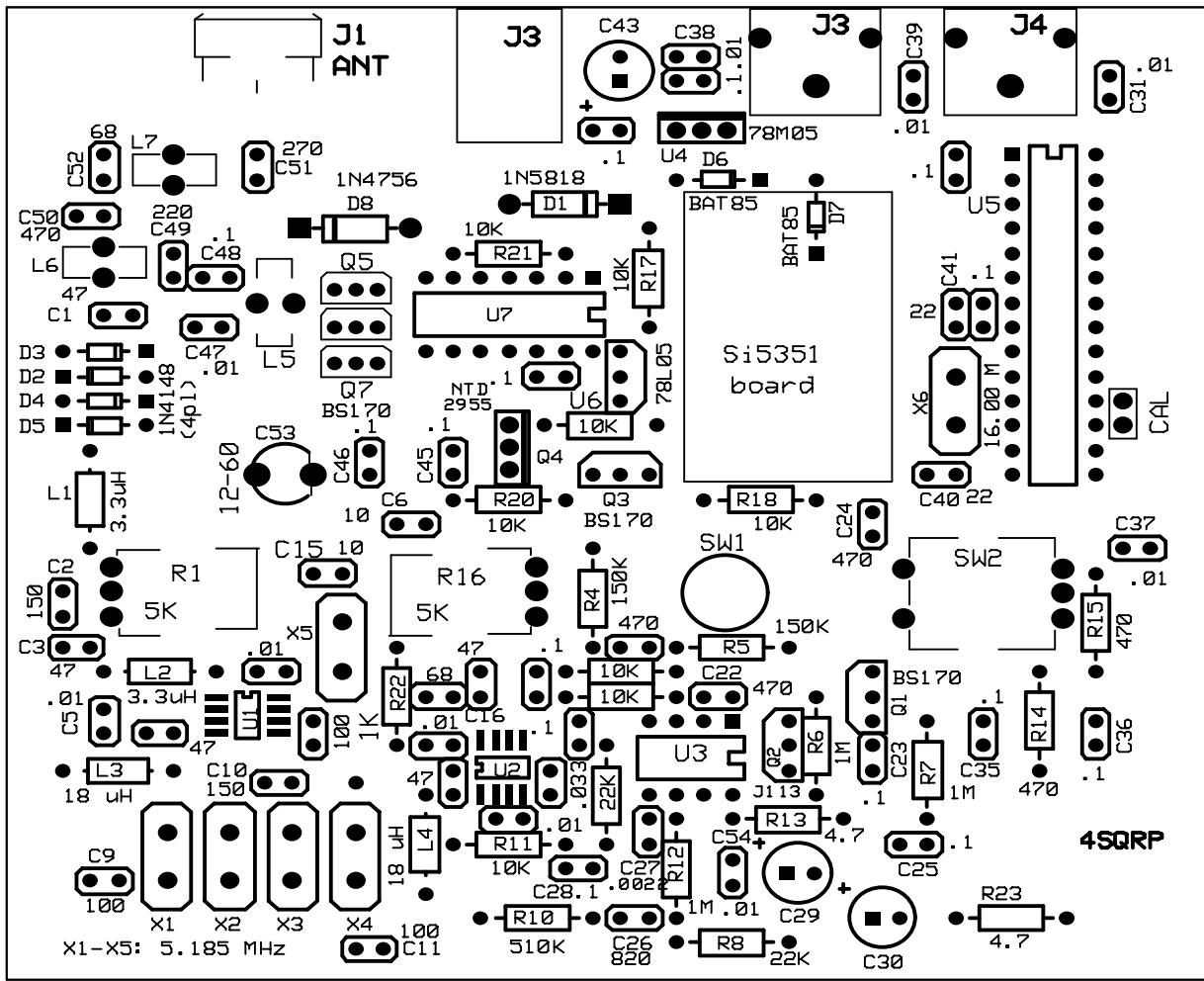

rev. 11/7/2017

Acknowledgements:

Thanks to Steve Weber- KD1JV whose SOTA POP design influenced the design of the transmitter section. He also graciously provided open-source firmware..... which I proceeded to mangle for this project.

Thanks also to David Cripe- NMOS- who played an invaluable role with enclosure layout, technical liason with 4SQRP, and provided advice with component selection.

Dave Benson, K1SWL 14Nov. 2017